

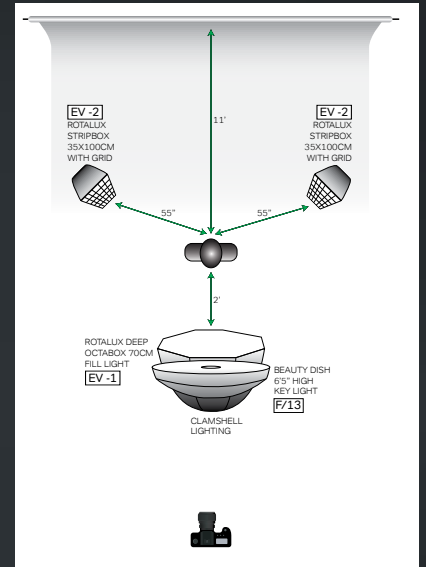

TWENTY FIVE LIGHTING DIAGRAMS TO SPARK YOUR CREATIVITY AND GROW YOUR SKILLS IN THE STUDIO



LIGHTING DIAGRAMS

GO-TO LIGHTING SETUPS WITH
MARK WALLACE

LESSON 3: HIGH CONTRAST PORTRAIT. FIRST SETUP

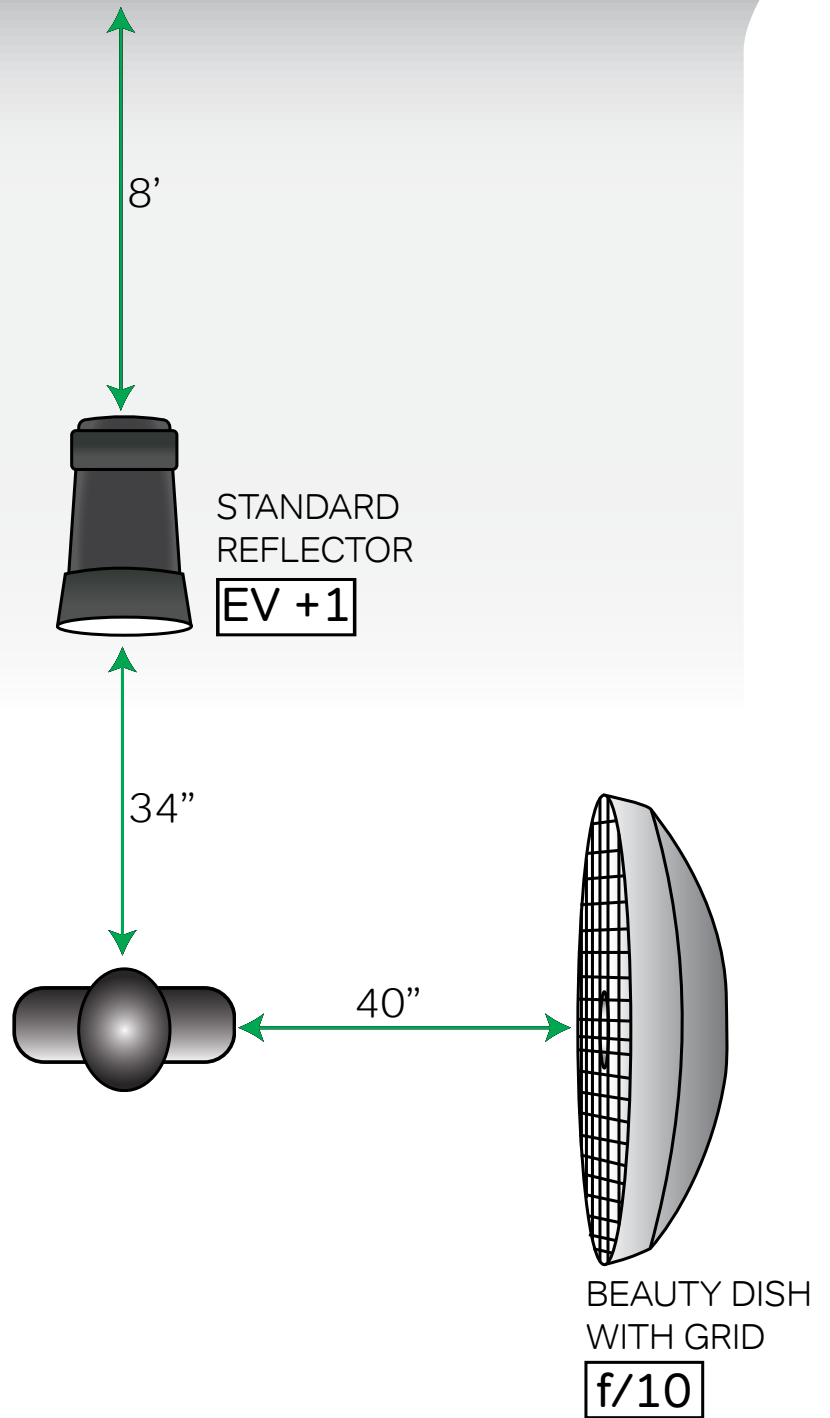

LESSON 3: HIGH CONTRAST PORTRAIT. SECOND SETUP

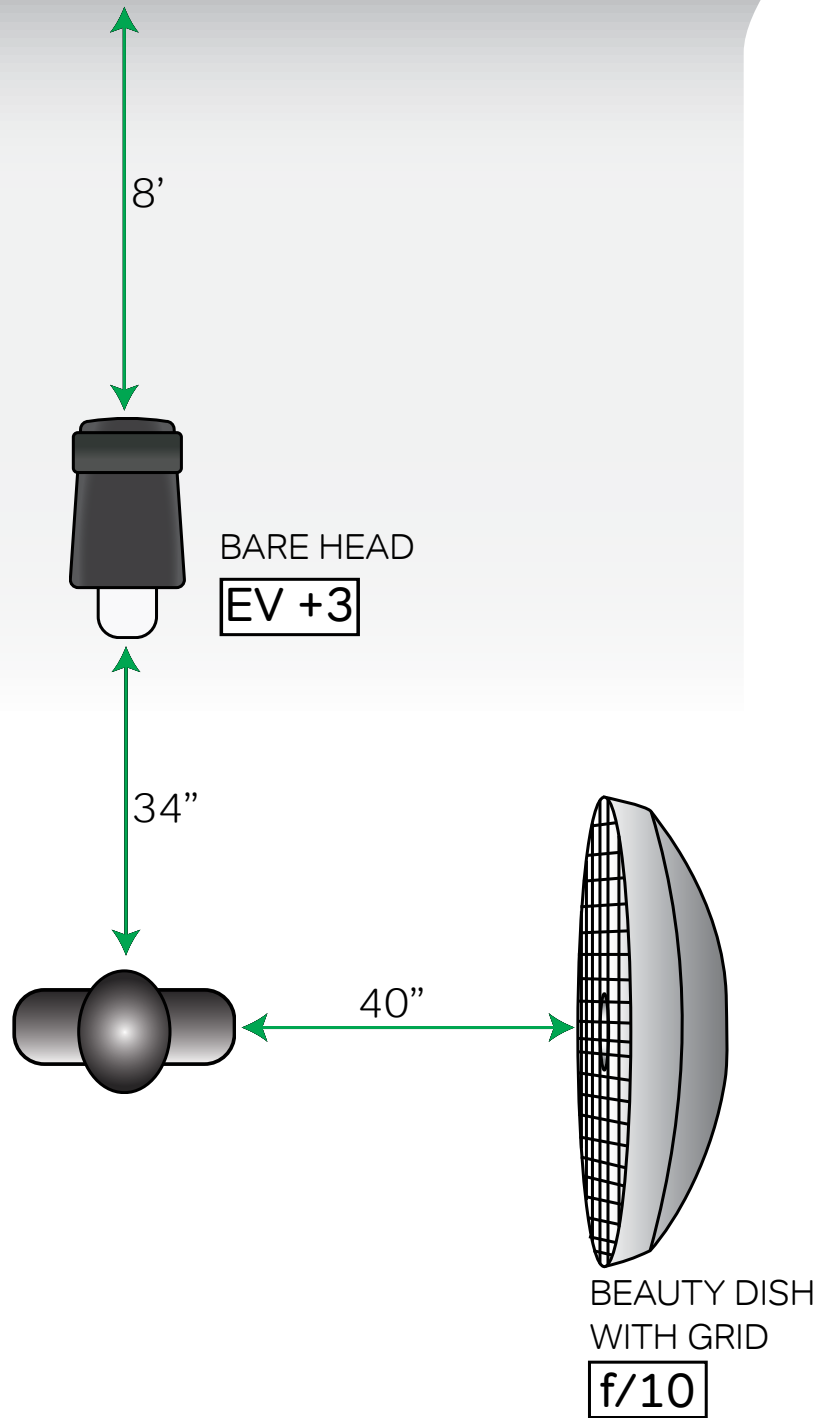

LESSON 3: HIGH CONTRAST PORTRAIT. THIRD SETUP

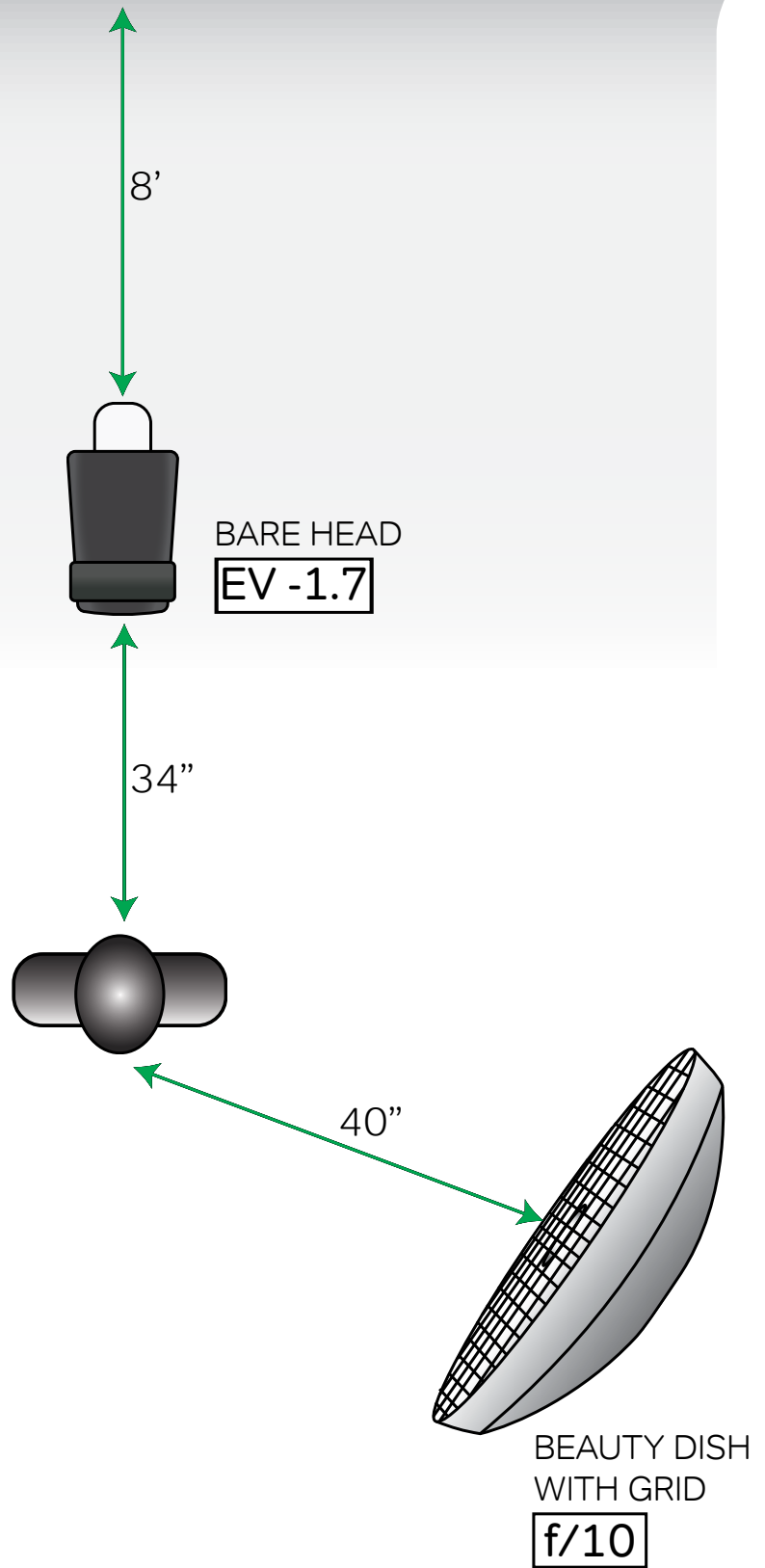

LESSON 4: FINDING THE LIGHT

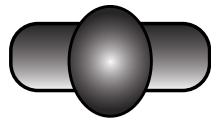
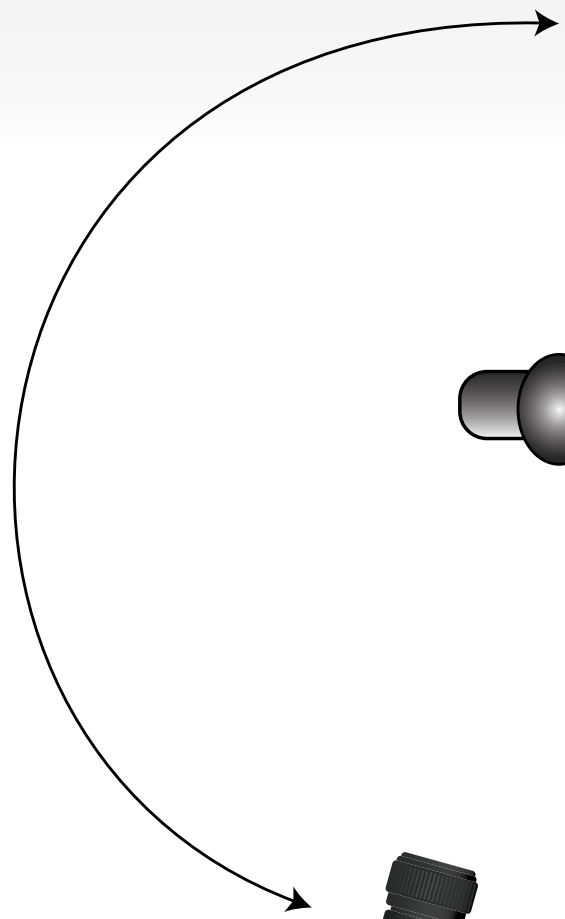
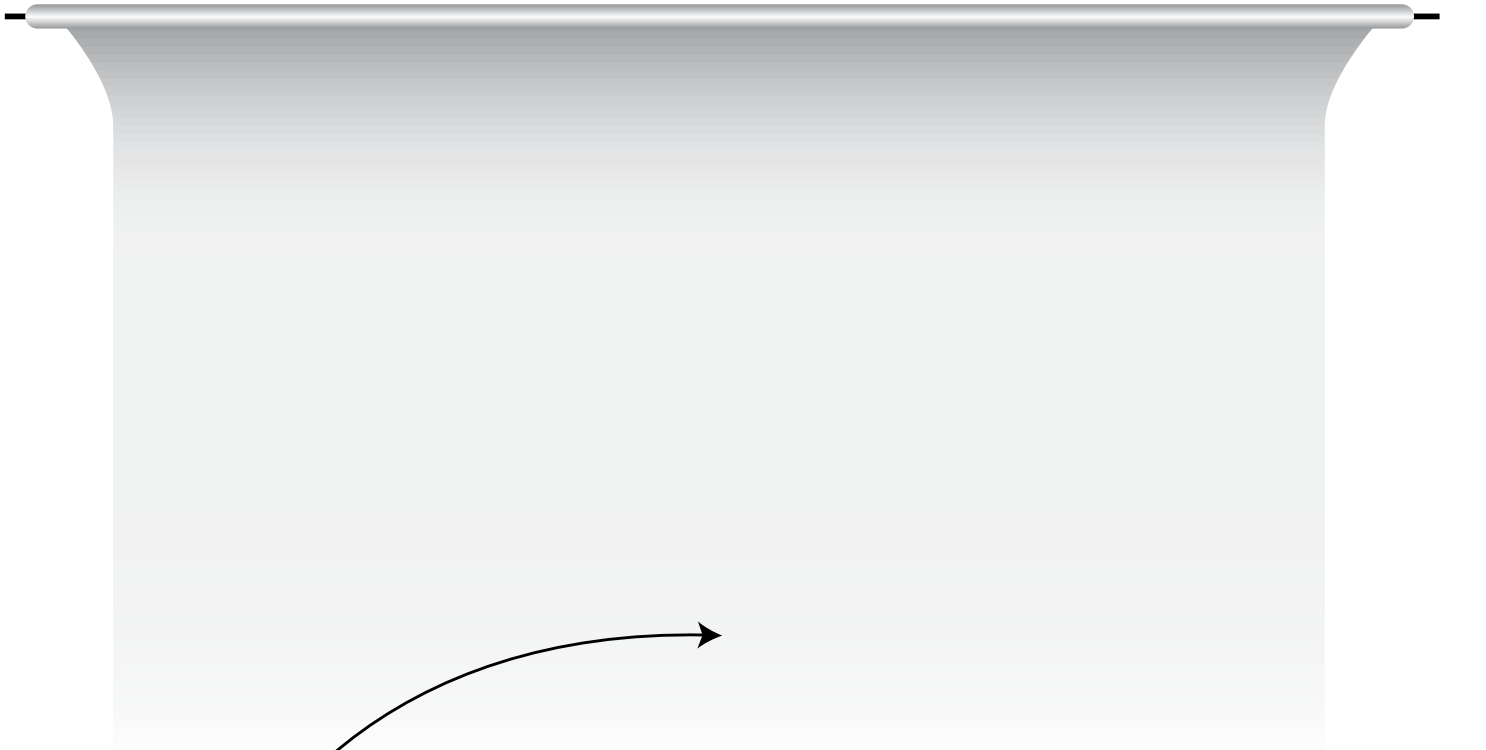

3'

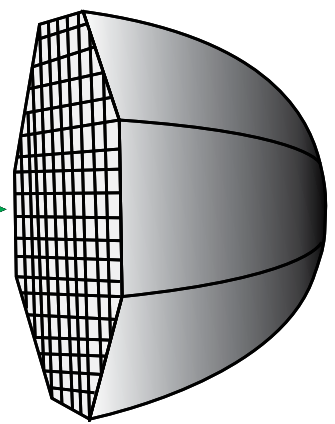

ROTALUX DEEP
OCTABOX 70CM
WITH GRID

f/8



CAMERA MOVES
AROUND MODEL



LESSON 5: SUBTLE BEAUTY

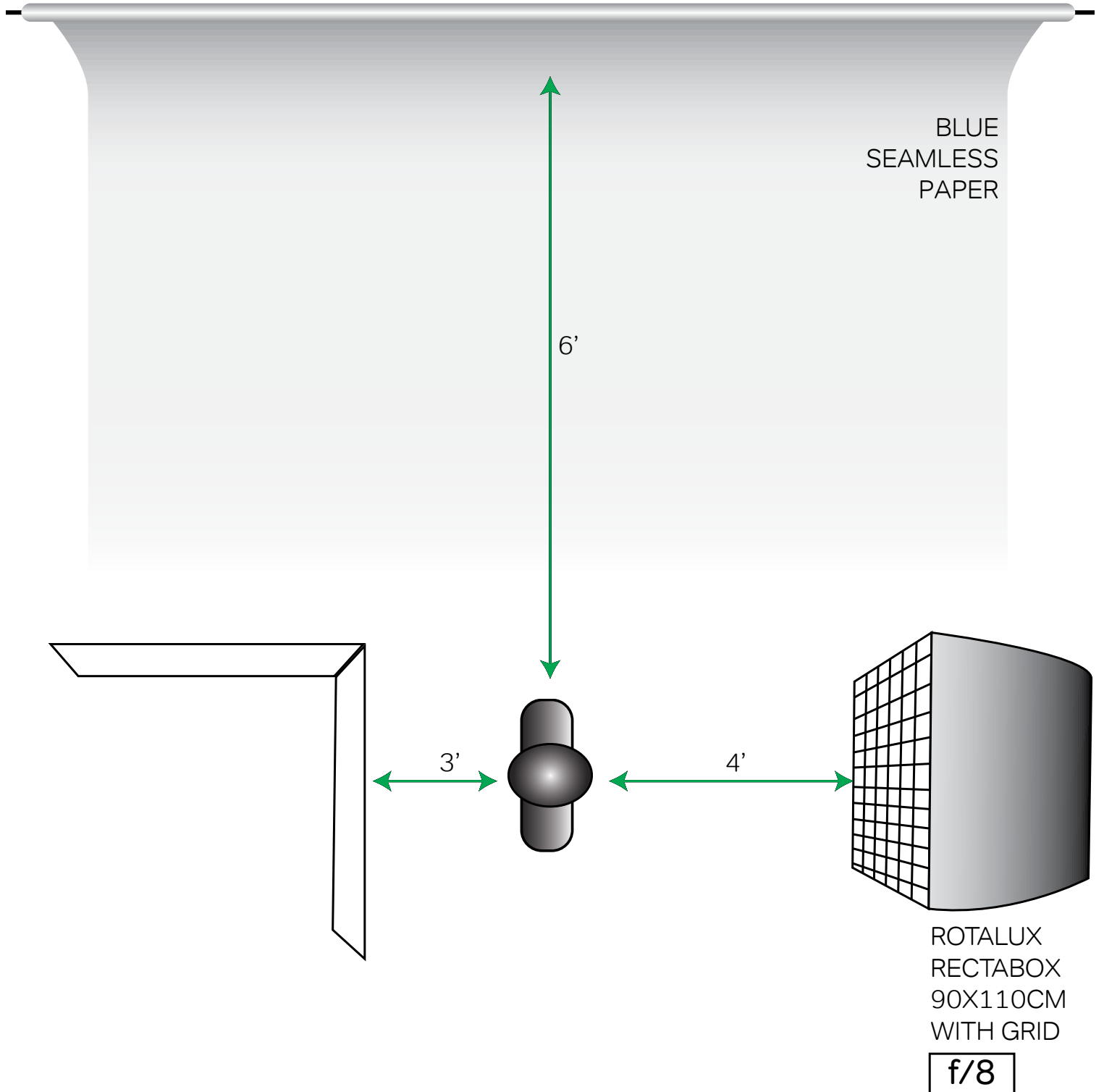

LESSON 6: SILVER SCREEN MAGIC

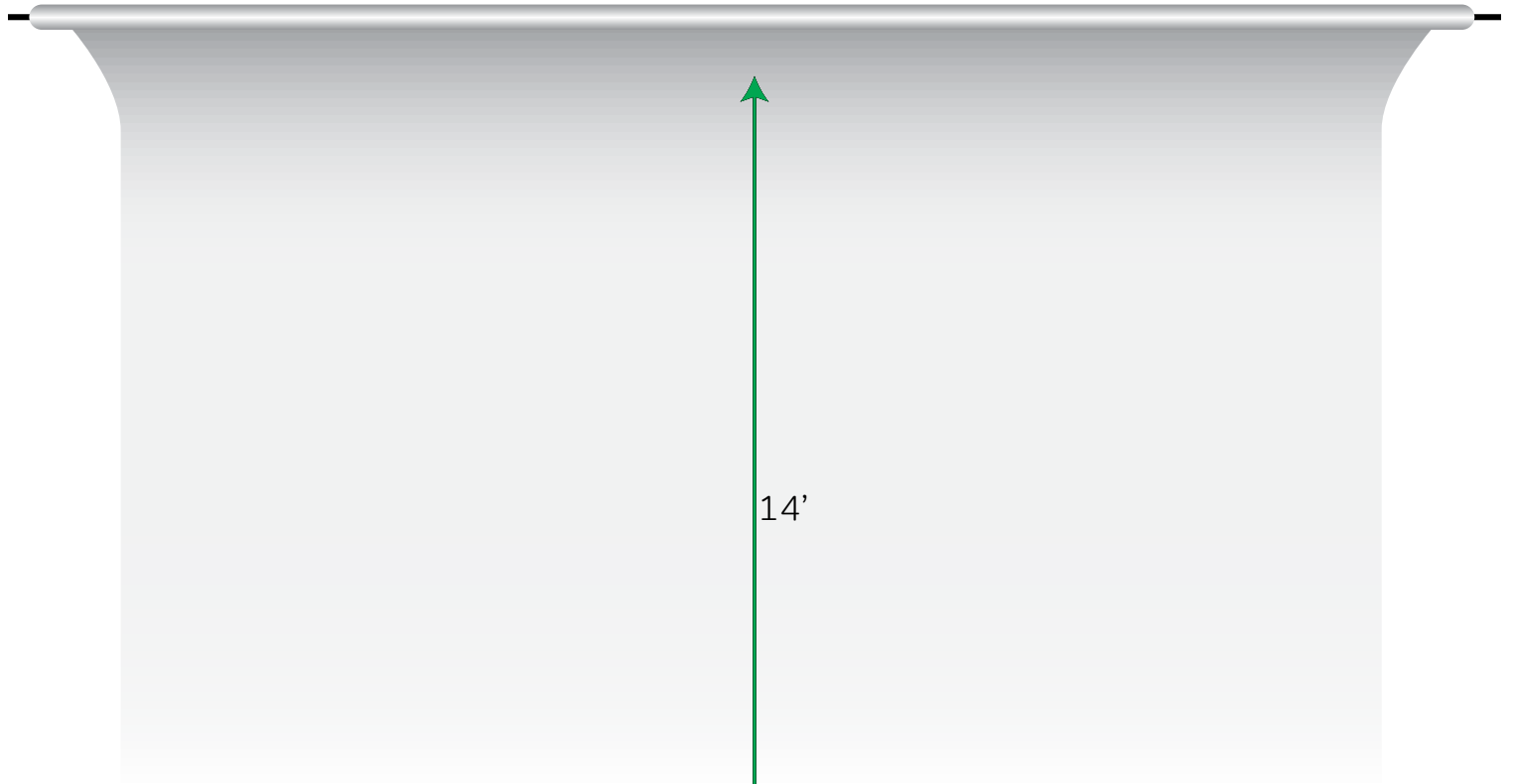

14'

SILVER WINDOW SCREEN

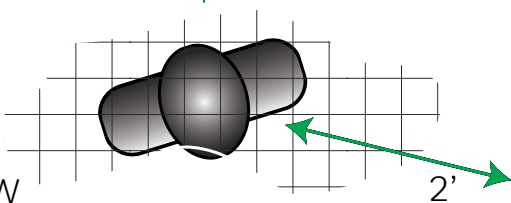

2'

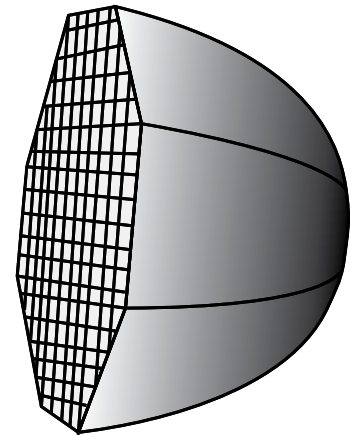

ROTALUX DEEP
OCTABOX 70CM
WITH GRID

f/10



LESSON 7: COLOR ON WHITE

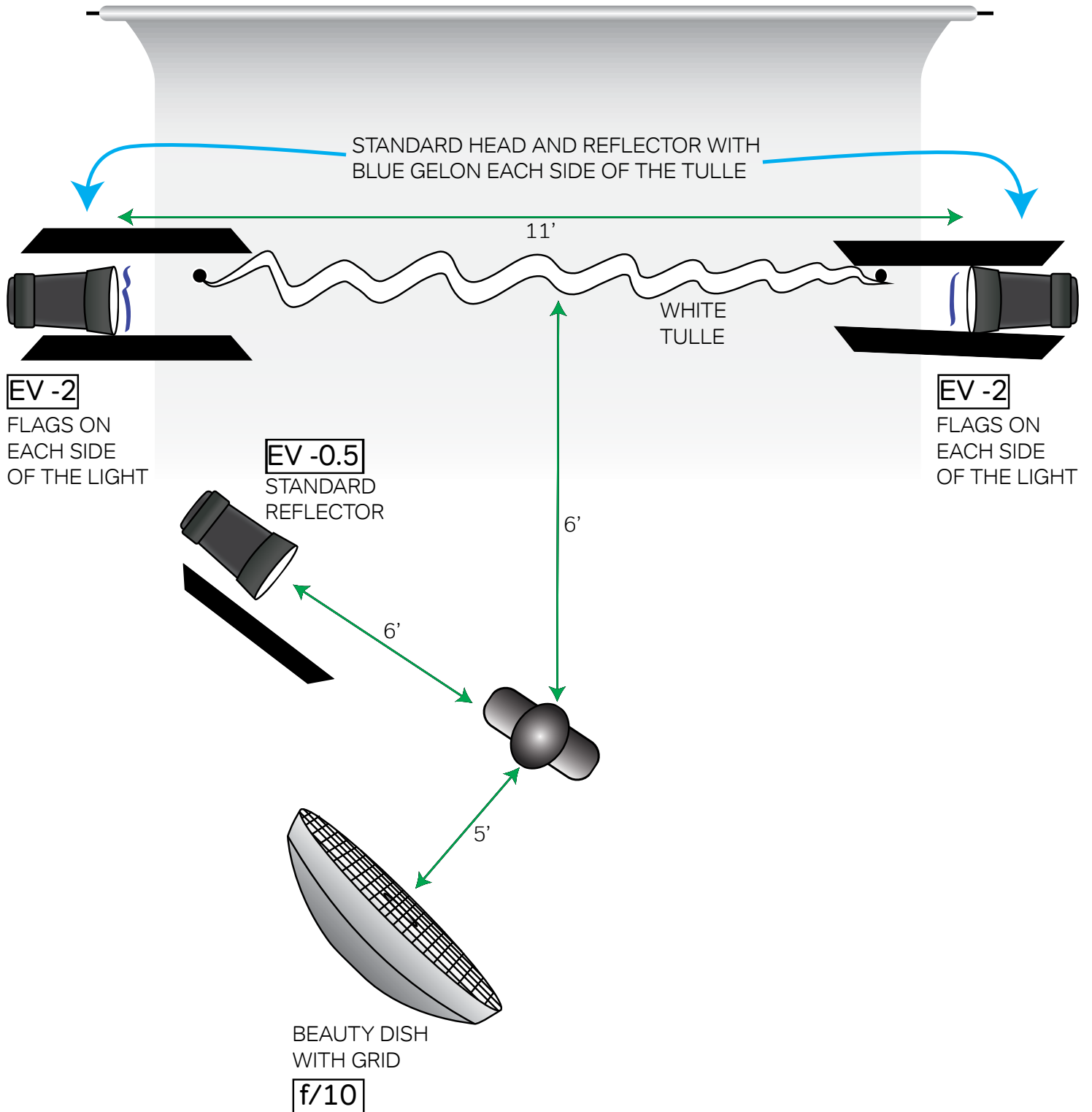

LESSON 8: CATALOG SHOTS

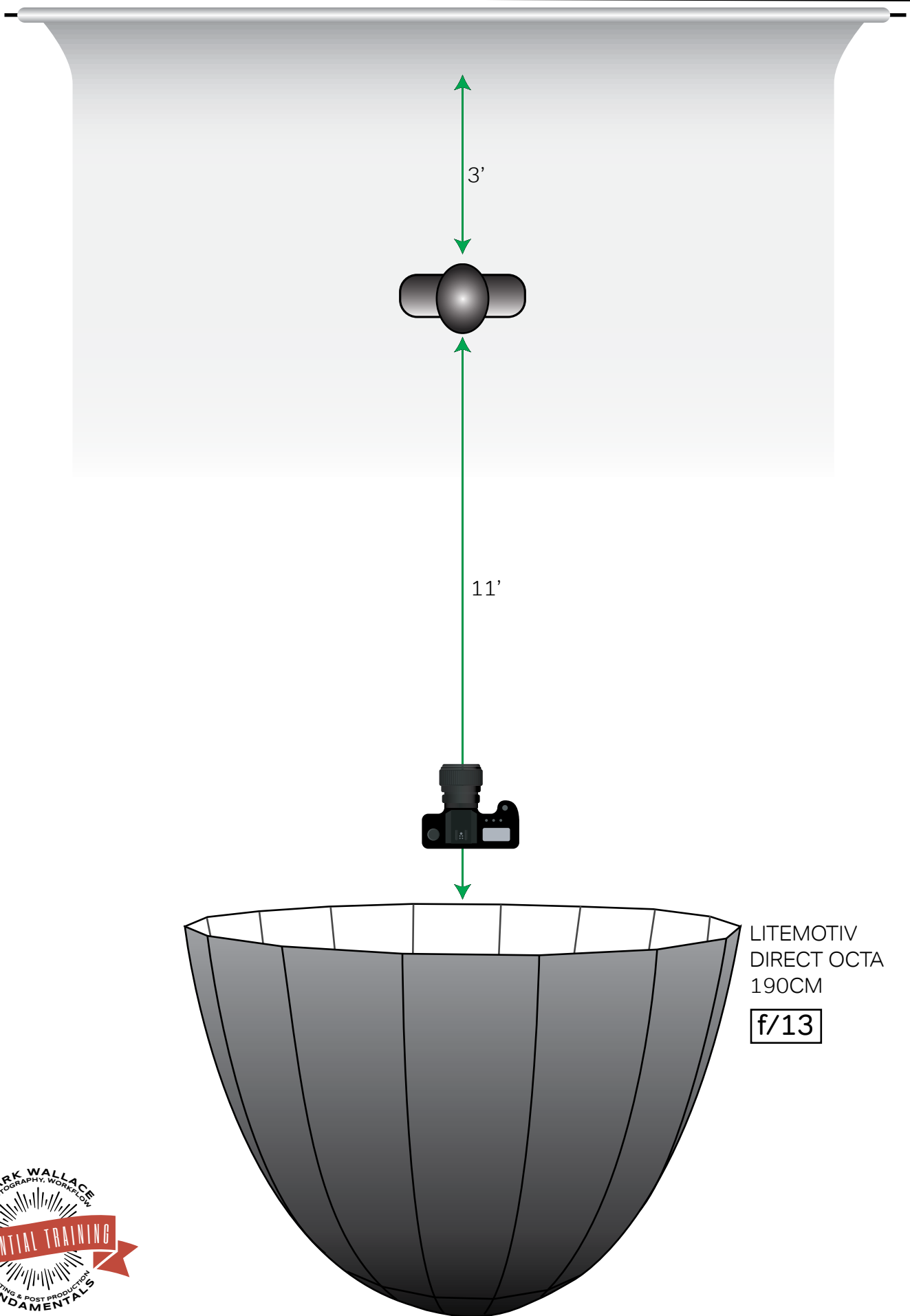

LESSON 9: LIGHT FROM BELOW

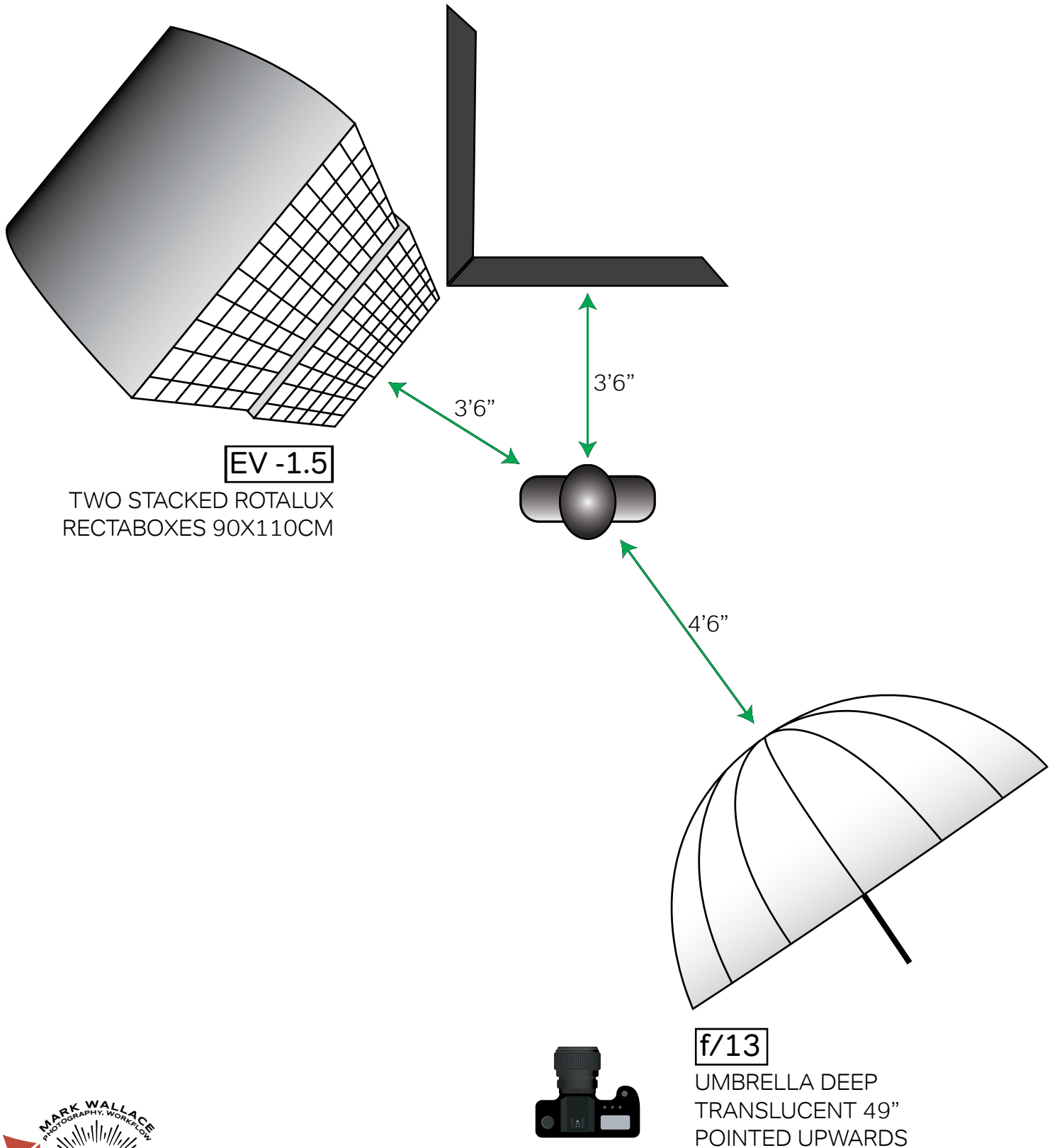

LESSON 10: FRESNEL BEAUTY

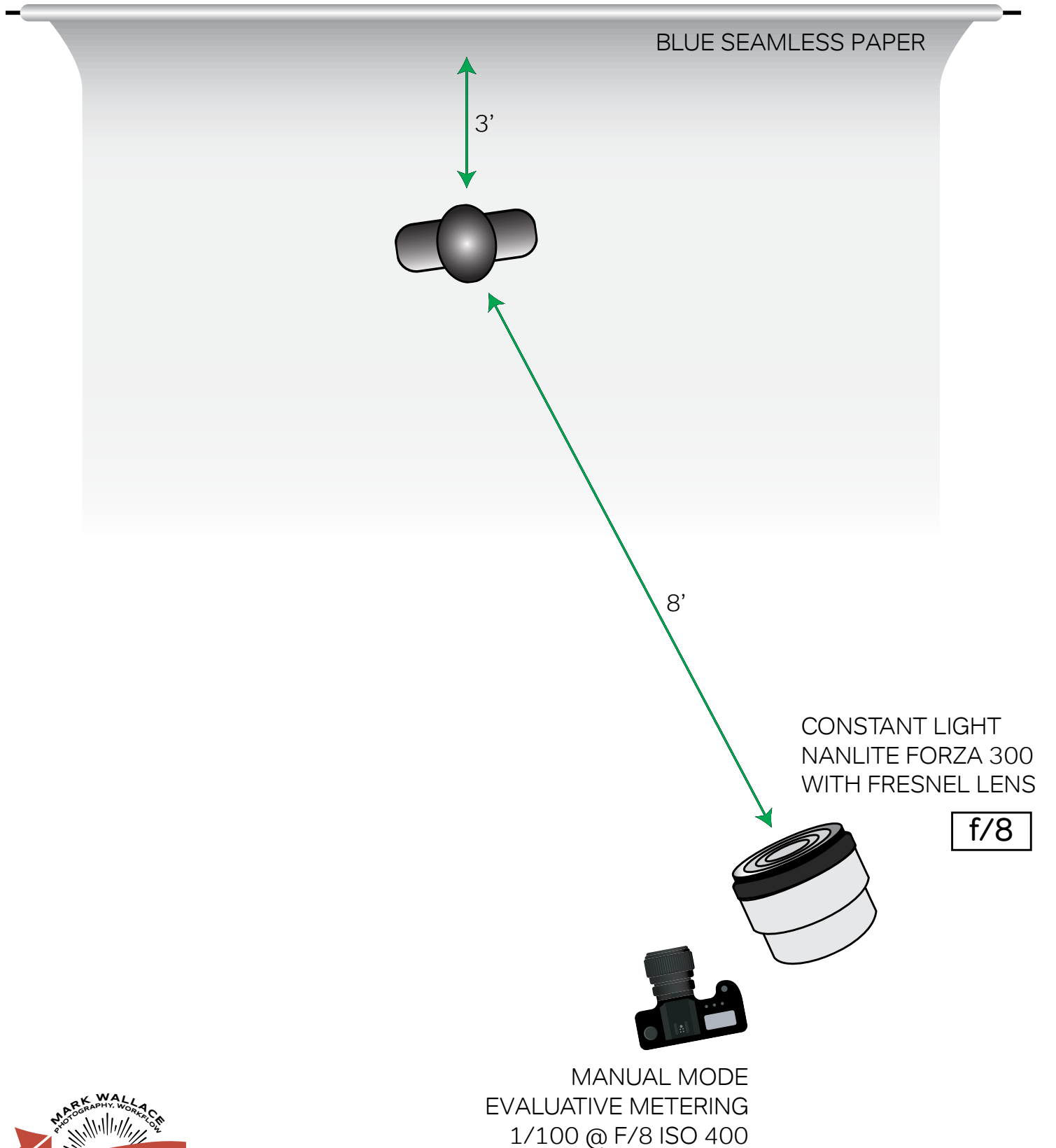

LESSON 11: OLD-TIME FASHION

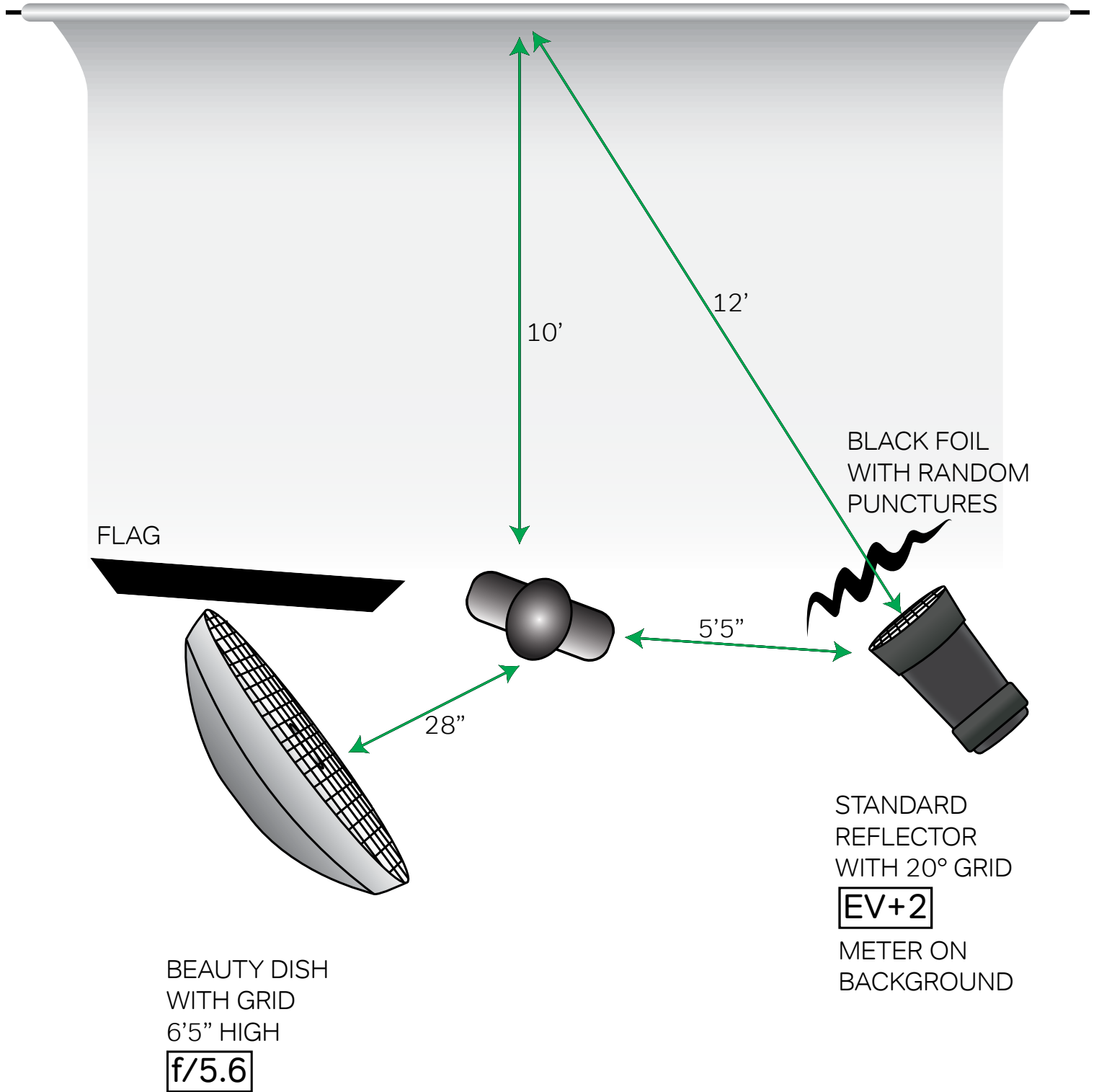

LESSON 12: SUPERHERO LIGHT

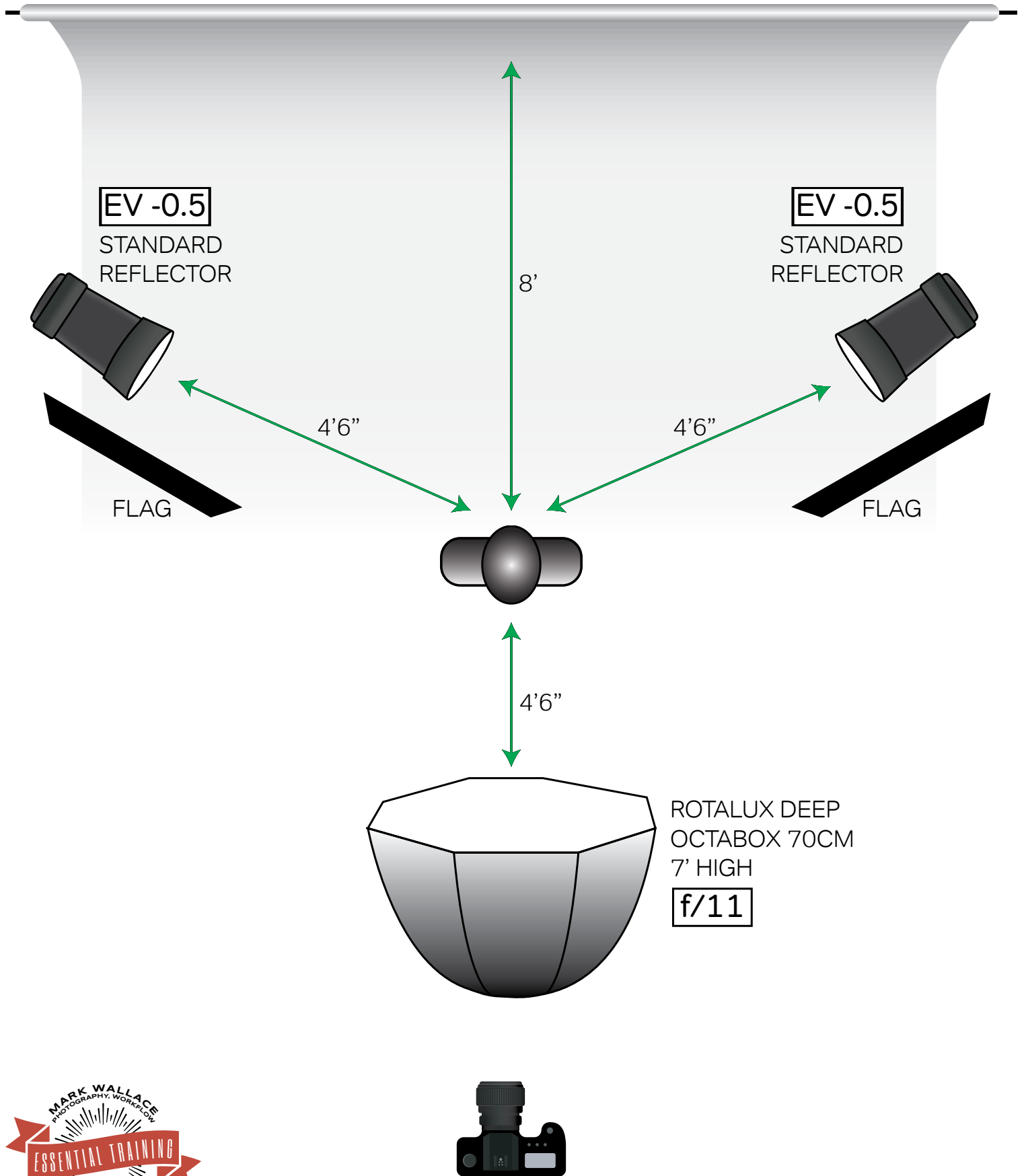

LESSON 13: SIMPLY STUNNING BEAUTY

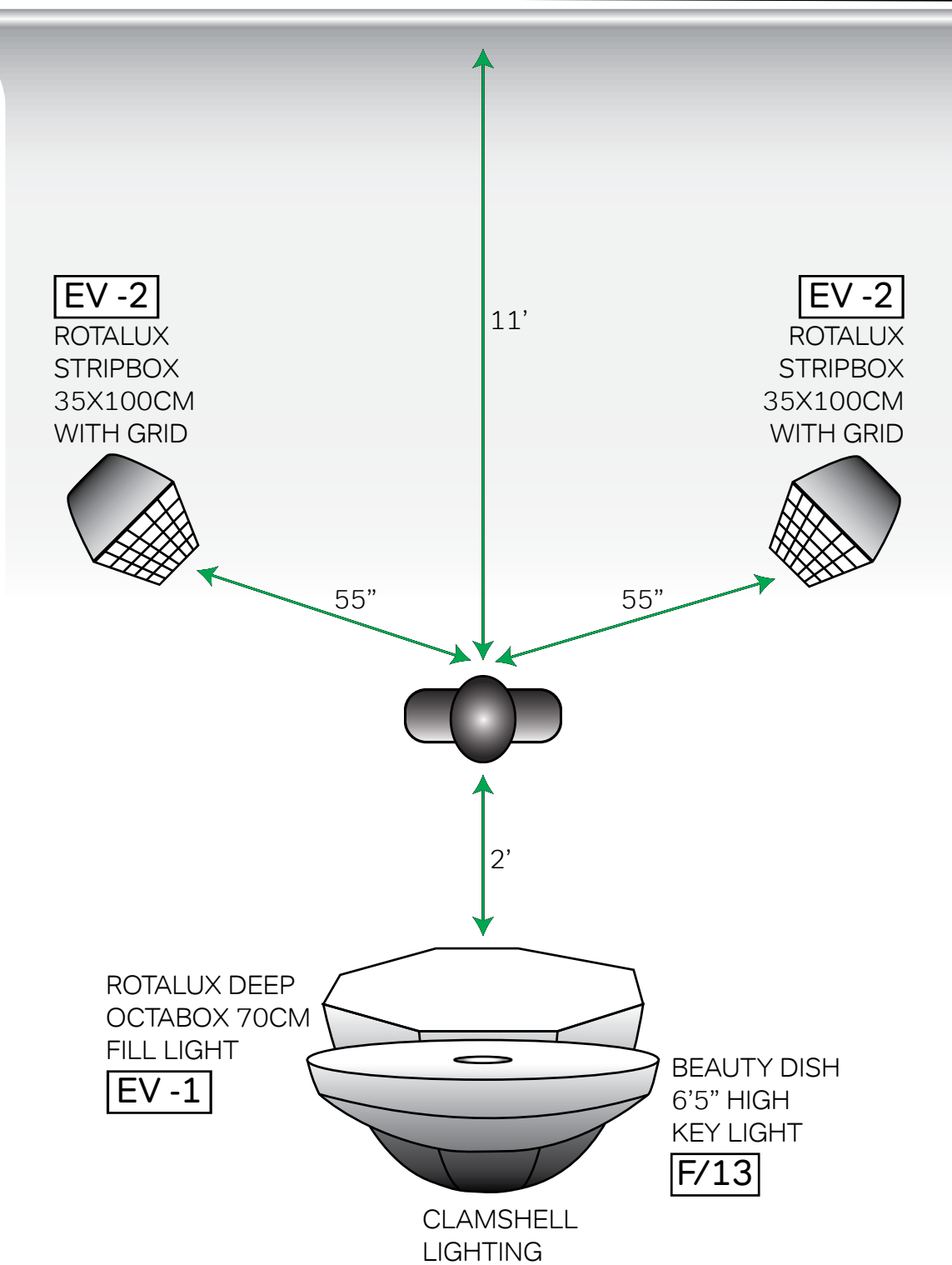

LESSON 14: CONTROLLING SHADOWS

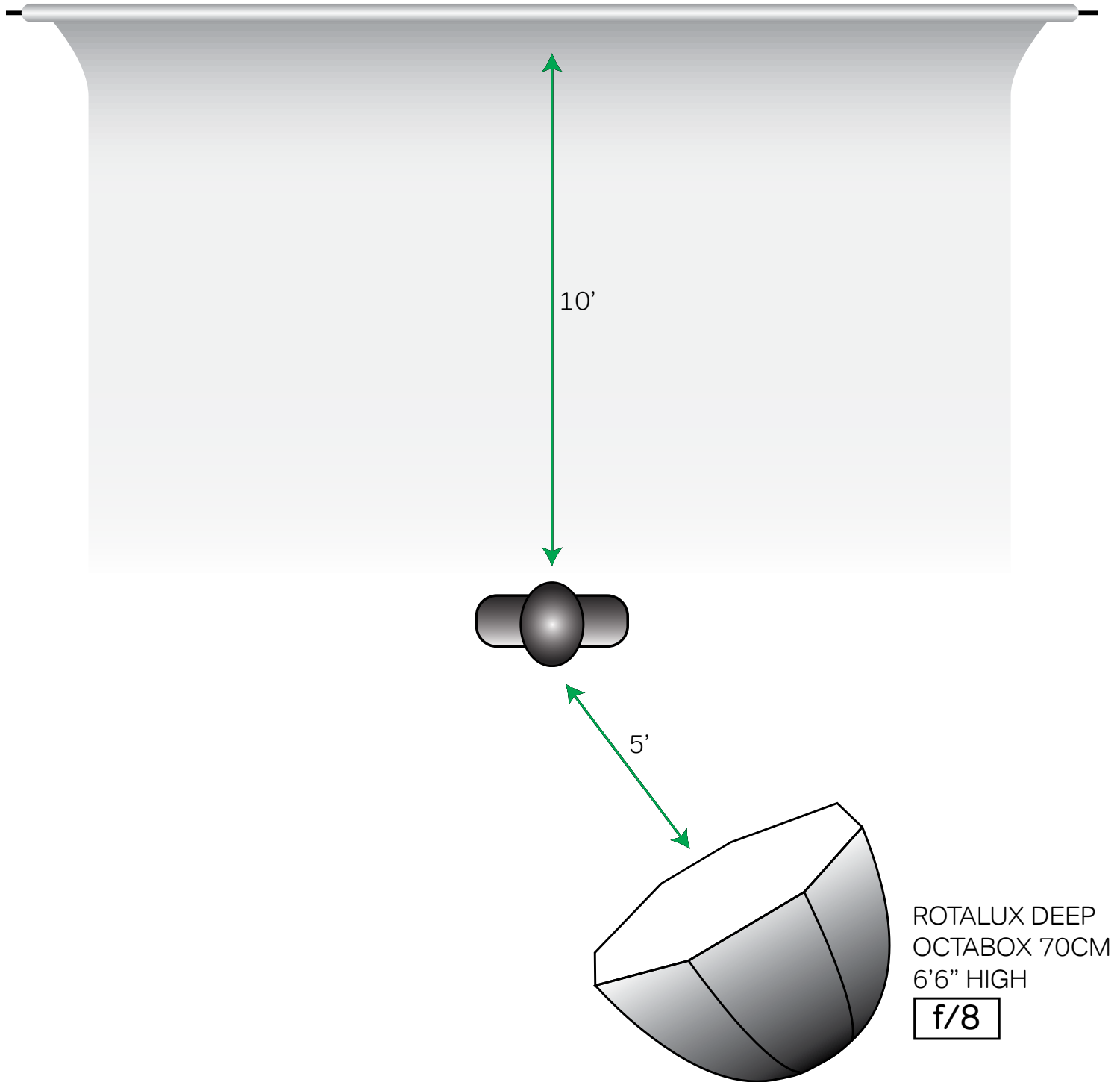

LESSON 15: SOFT FINE ART

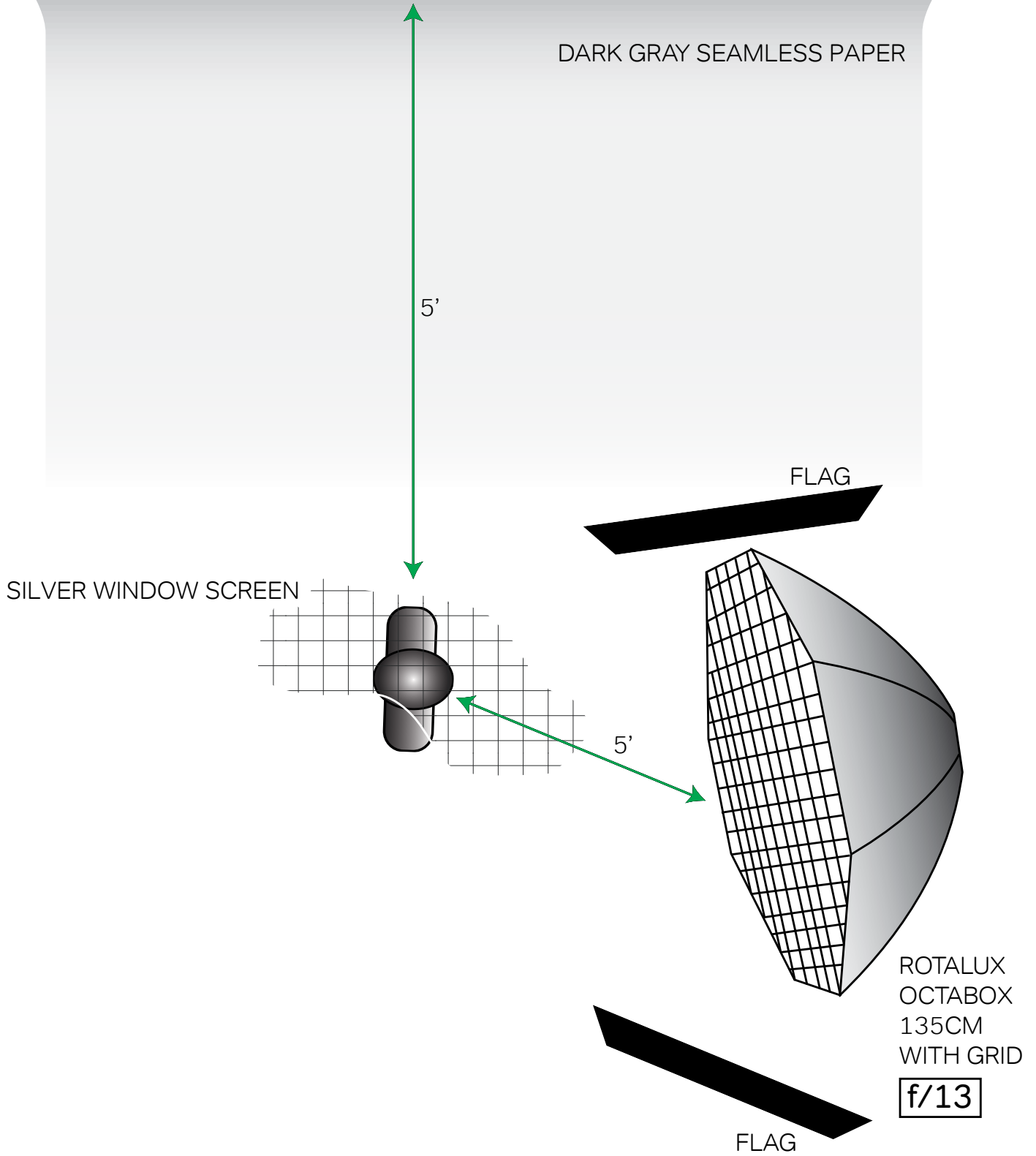

LESSON 16: FRONT BOKEH

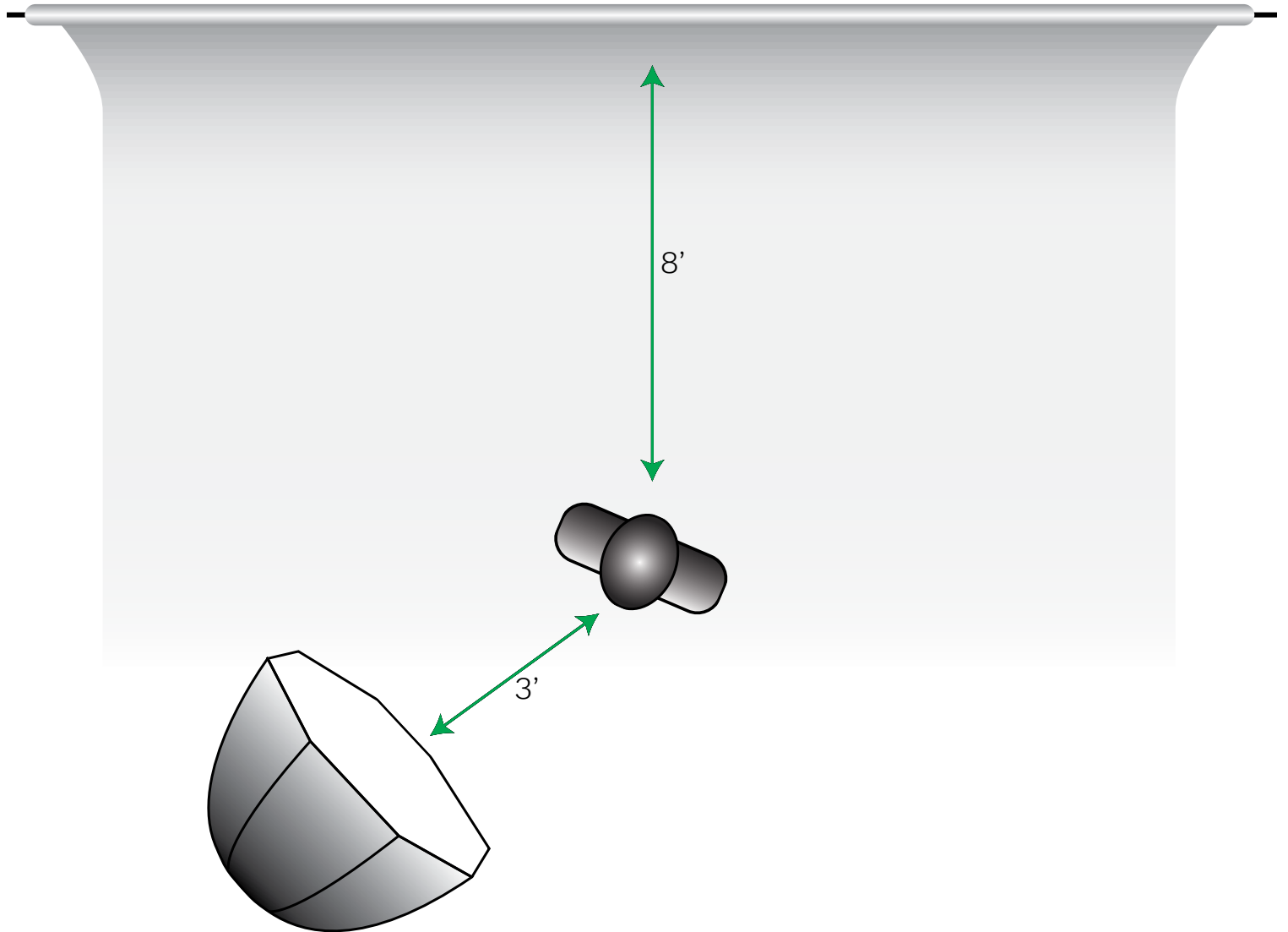

CONSTANT LIGHT
FORZA 60B @ 5200K
SMALL OCTABOX

f/1.2



LED HOBBY LIGHTS



MANUAL MODE
EVALUATIVE METERING
CANON 85MM F/1.2 L
1/160 @ F/1.2 ISO 100



LESSON 17: LARGE SOFT LIGHT, THE EASY WAY

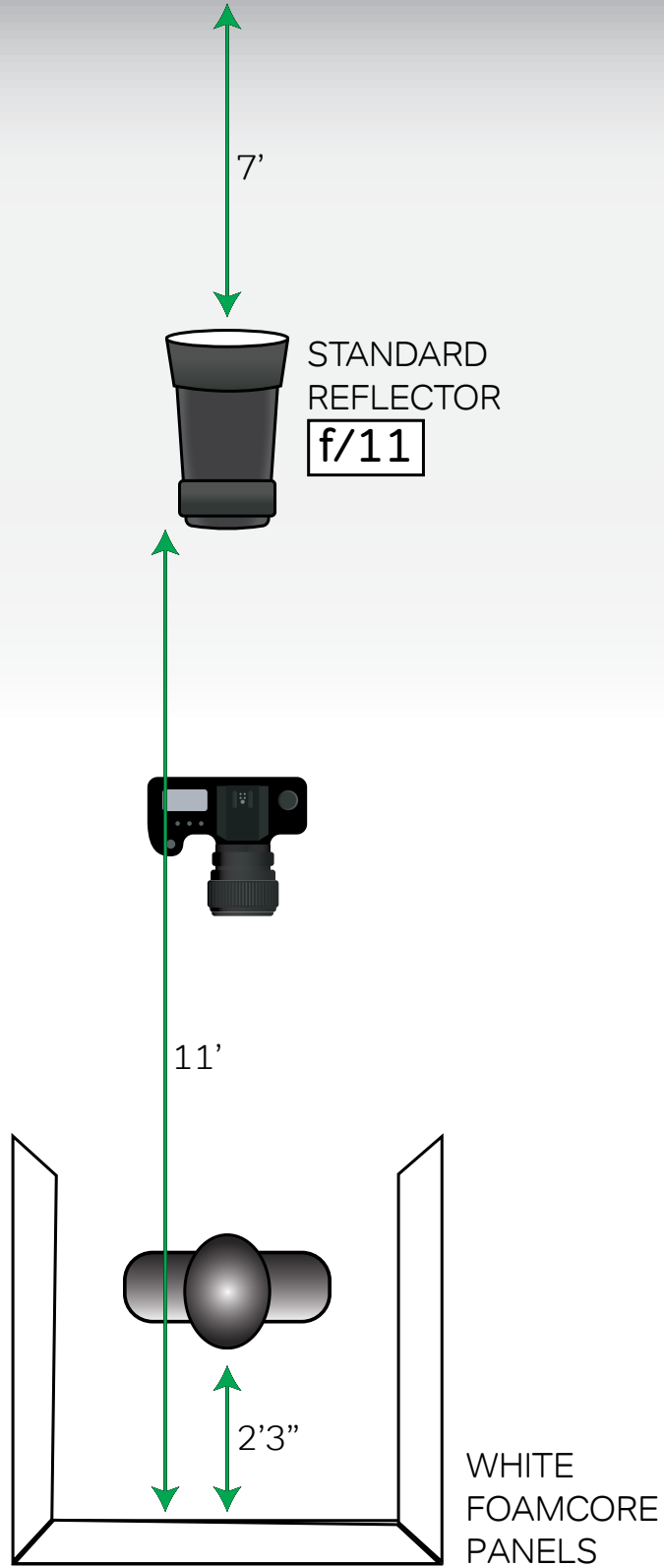

LESSON 18: CREATING MOTION

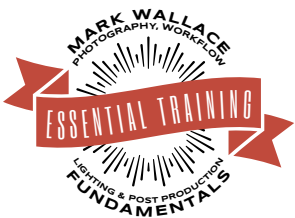
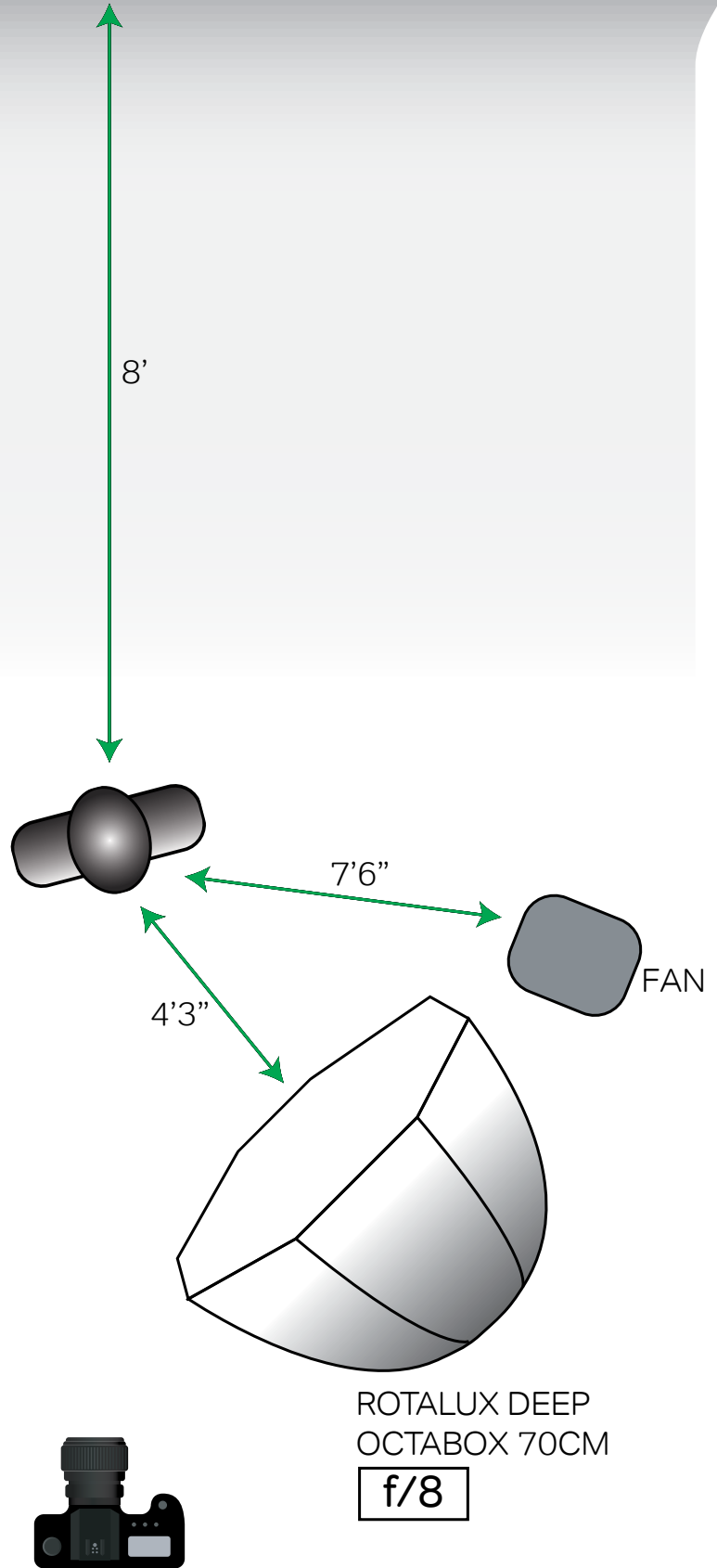

LESSON 19: DRAMATIC LIGHT USING WHITE BALANCE SHIFTS

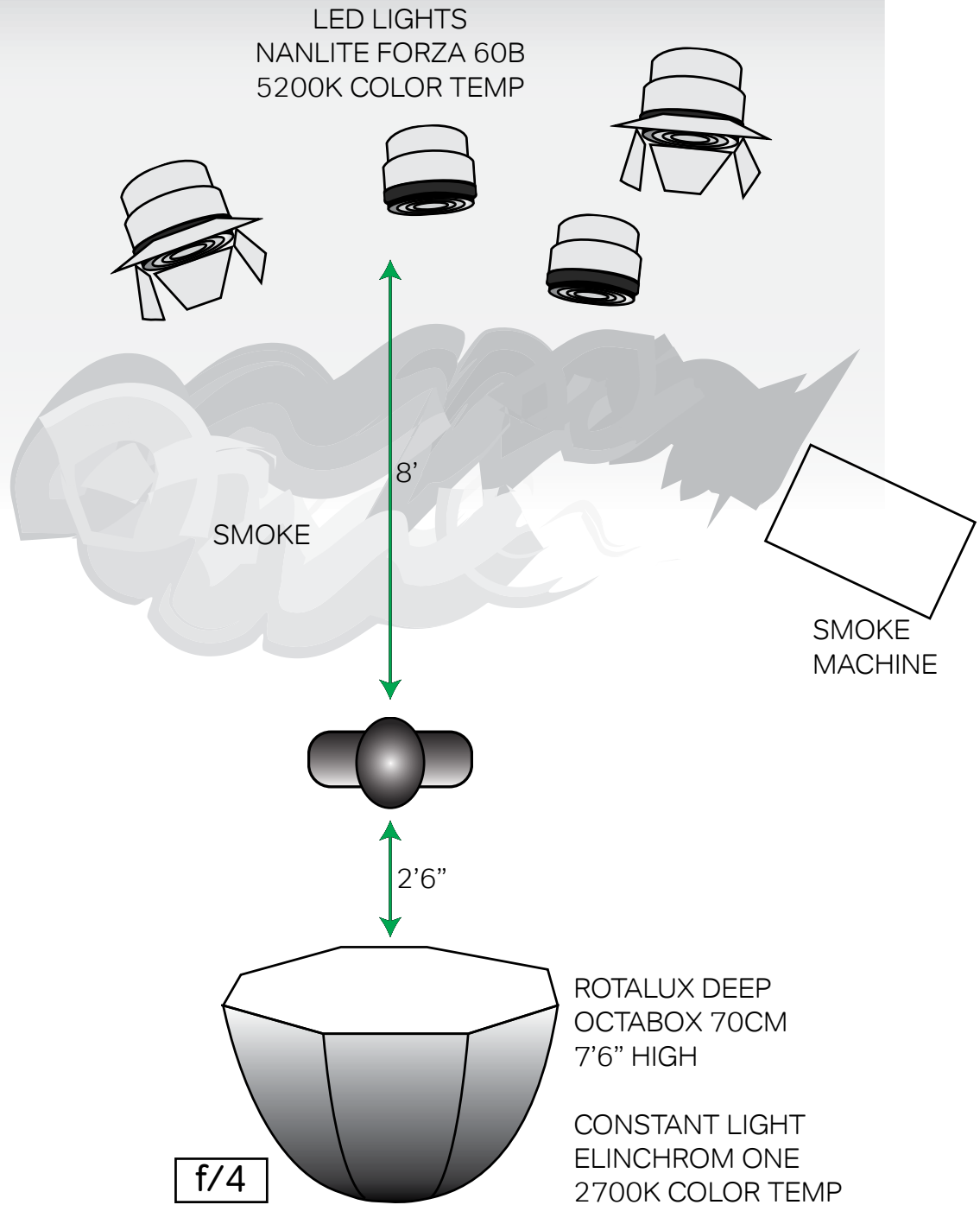

MANUAL MODE
EVALUATIVE METERING
1/100 @ F/4 ISO 5000
WB 2700K

LESSON 20: SIMPLE SOFT LIGHT

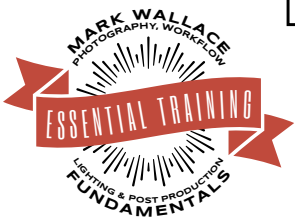
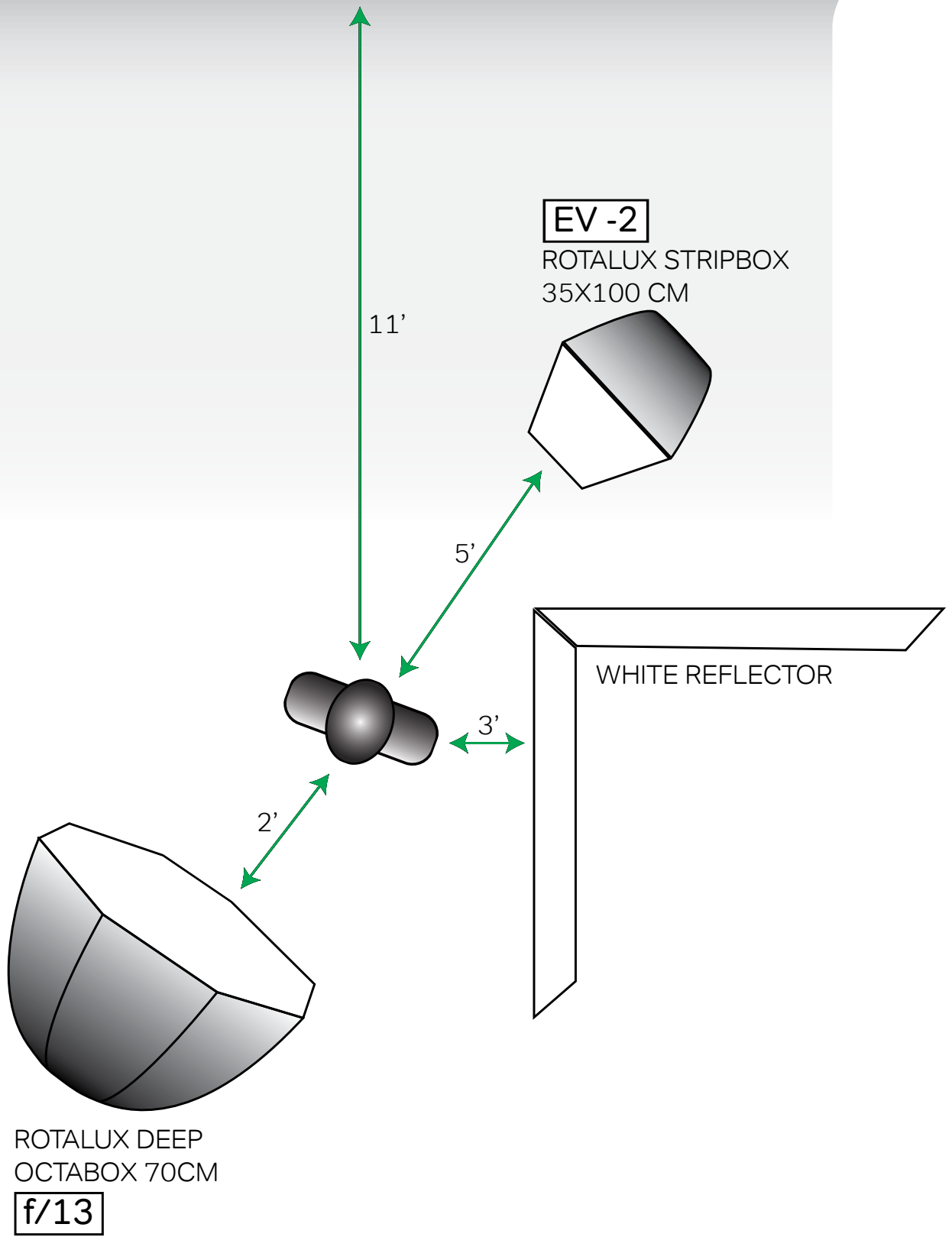

LESSON 21: GRINDER GIRL

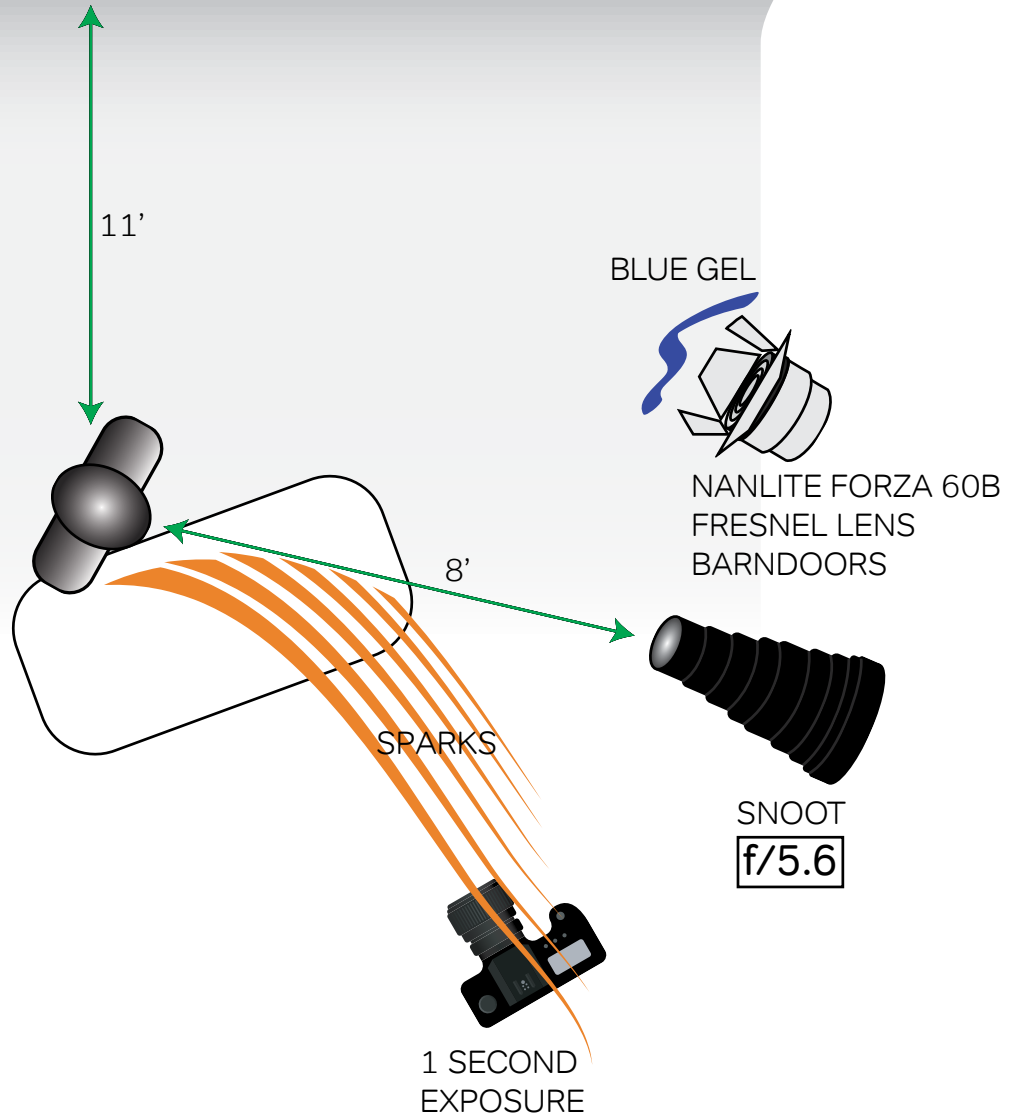

LESSON 22: LARGE SOFT LIGHT

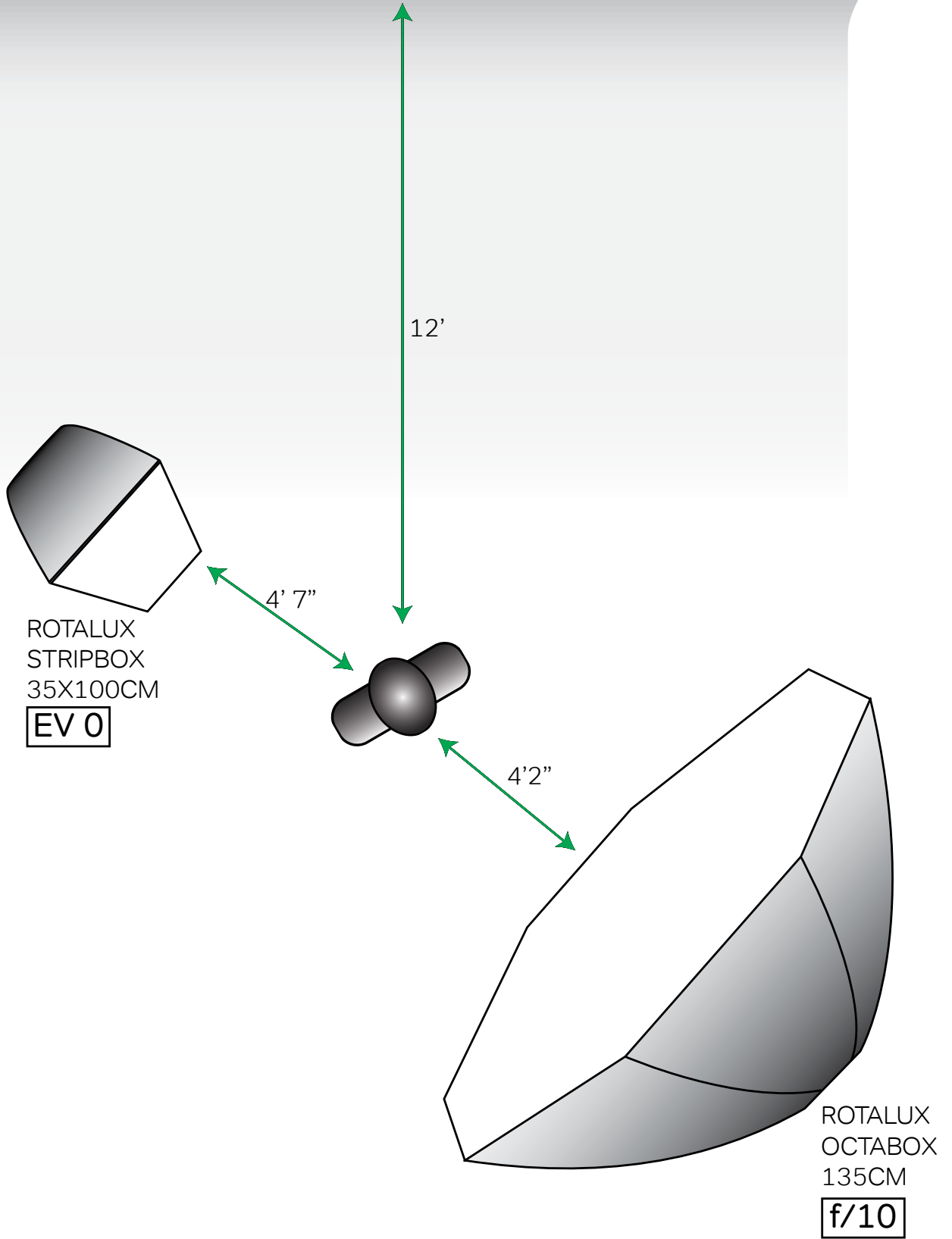

LESSON 23: VERTICAL CONTRAST

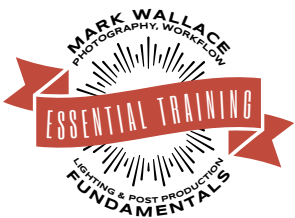
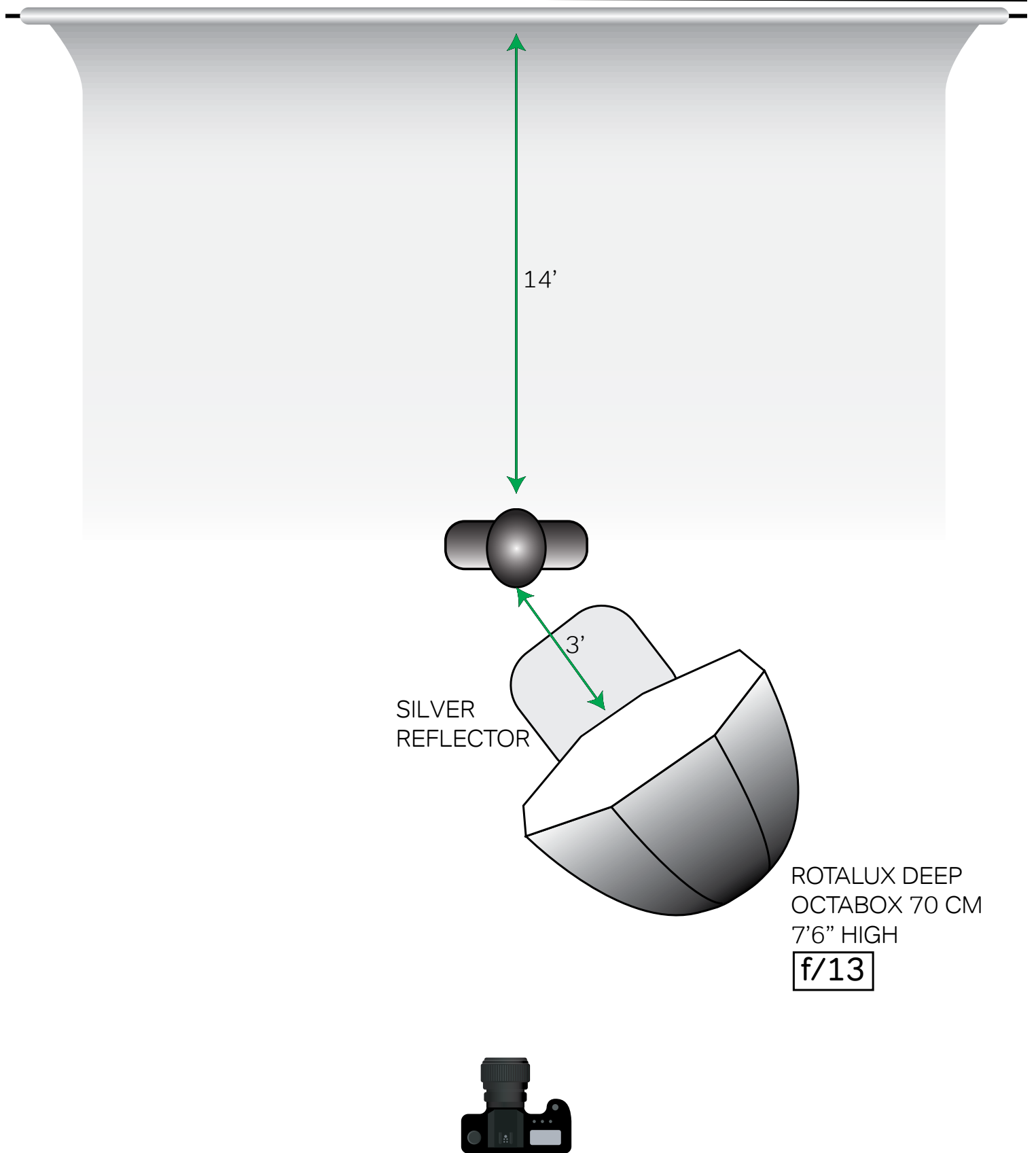

LESSON 24: LIGHT RAYS

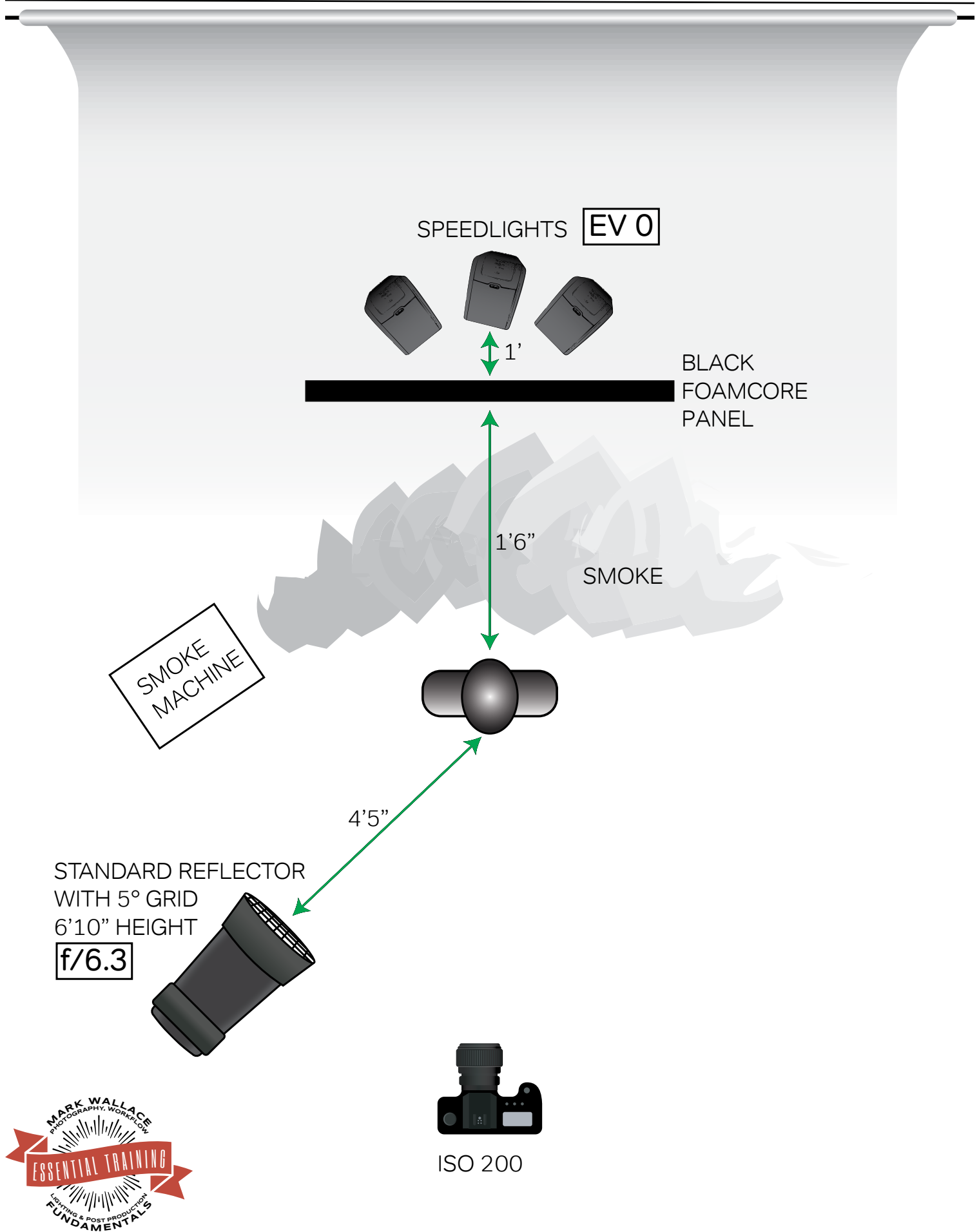

LESSON 25: WIDE ANGLE TEXTURE

